

# Analysis of VHF-wideband Impulsive Electromagnetic Noises from Power Distribution Lines

Student Member Ampol Tungkanawanich (Osaka University)  
Member Zen-Ichiro Kawasaki (Osaka University)

Impulsive electromagnetic noises, generated by electrical discharges on power distribution lines, are mainly responsible for wide-band disturbances to communication systems. In this paper, the impulsive noises emitted from various discharge sources are analyzed. We employed a non-contact measurement system using the VHF wide-band antenna, which permits not only the waveforms of electromagnetic pulses but also the timing of pulses. By using this system, we measured the pulses generated by applying high voltage upon the discharge sources. The characteristics of a single pulse waveform are analyzed by digital signal processing techniques, which are Fourier and wavelet transforms. Moreover, the time-sequential pulse-height patterns of pulses are investigated. The pulse-height and pulse-repetition of both positive and negative pulses are discussed associating with the mechanism of discharge. It is shown that the results are useful to classify the kinds of discharge sources and assess the condition of insulators in distribution systems.

**Keywords:** impulsive noises, electrical discharges, wide-band detection, wavelet transform, time-sequential pulse-height (TSPH) analysis.

## 1. Introduction

Recently, a study of wide-band impulsive noises has been greatly considered as an important research due to the increasing use of wide frequency ranges, caused by the rapid growth of communication systems. The electrical discharge in high-voltage system is one of the main sources of impulsive noises<sup>(1)</sup>. Among all high-voltage systems, the power distribution lines cover very wide areas and locate nearest to the electricity customers, therefore the noises from them result in direct and great disturbances. Usually, the electrical discharges include both full and partial ones. The full discharges are generated by the electrical breakdown of insulation systems. And also, the partial discharges occur when there are abnormal electric field stress conditions or faulty equipment, which can further to electrical breakdown. To enhance the reliability of power system and the electromagnetic (EM) environment, the location and classification of impulsive noise sources should be done so that the appropriate action can be taken as soon as possible.

The location of discharge sources by using wideband antennas has been widely investigated<sup>(2)–(5)</sup>. In contrast, the researches concerning the classification of them are very few and insufficient. Naturally, the EM radiation from electrical discharge is generated by particles falling to lower energy states and shows the different feature depending on the kind and mechanism of a discharge source. Hence, the characteristics of emitted EM pulses are useful to classify the discharge. Unlike the narrow-band detection, the wide-band detection has an advantage to record nearly the true shape of an EM pulse, which is useful information to classify the discharge source. However, sometimes the information of

waveform of a single EM pulse alone is not sufficient to classify the discharge source because of its sensitive phenomenon and the large distribution of characteristics in some cases. The other information, such as the statistical pattern of EM pulses, should be additionally investigated.

In this paper, we analyze a lot of EM pulses or so called *pulse-train electromagnetic waves* emitted from various discharge models. We employed a non-contact measurement system using the VHF wide-band antenna, which permits not only the waveforms of EM pulses but also the timing of pulses. By using this system, we measured the discharges generated by applying high voltage on various discharge models, such as needle-plane electrode, plane-plane electrode and faulty insulators. The characteristics of a single pulse waveform are analyzed by digital signal processing techniques, which are Fourier and wavelet transforms. Moreover, the time-sequential pulse-height (TSPH) patterns of pulses are investigated. Some results are shown and discussed. The mechanisms of the discharges are additionally explained based on the obtained results. By using the experimental data, it is shown that the results are useful to classify the kinds of discharge sources and assess the condition of insulators in distribution systems.

## 2. Experiment

**2.1 Method** The discharge from power distribution lines is concentrated. Figure 1 (a) shows the discharge generating models used in the experiment. As for 6.6 kV system, the phase voltage is 3.81 kV so we applied 60 Hz ac high voltage 4 kV upon five kinds of discharge sources, which are needle-plane electrode (0.5

mm gap), plane-plane electrode (circle planes whose radii 1.5 and 4 cm, 0.5 mm gap), needle-plane electrode with resistances ( $R = 2 \text{ G}\Omega$ ) on both ends, strain insulators (faulty contact) and a cracked pin-type insulator. In order to generate the discharge, the faulty contact was constructed by wrapping the insulated tape around a cotter pin (the pin used to combine two strain insulators together). In case of a cracked pin-type insulator, we poured some gel and water on its surface in order to generate the discharge easily. We also further applied dc high voltage 4 kV on the needle-plane electrode to compare with ac high voltage results.

Figure 1 (b) shows the circuit used to generate the ac high-voltage in this experiment. In the low-voltage side, the input voltage can be adjusted in range 0-130 V by sliding regulator and will be transformed to high-voltage by using neon transformer (Matsushita: No.TN-150CHAYSA, 160 VA, 100 V-15 kV/60 Hz). Note that the resistance  $1 \text{ M}\Omega$  was inserted before the discharge source in order to prevent the flowing of great current when the circuit accidentally shorted. In case of dc high-voltage source, the dc power supply (Kansaiden-shi: No.AKT-10K06P/100, Input: ac 100 V, Output: dc 0-10 kV/600  $\mu\text{A}$ ) was used.

Figure 2 shows the experimental configuration. The experiment was done on the outdoor roof of a building where is plain and free of obstacles. The discharge source was positioned at 15 m far from the VHF-wideband capacitive plate antenna.

**2.2 Measurement setup** The EM signals received at antenna were passed through the band-pass filter (25-250 MHz) and monitored at digital storage oscilloscope (DSO: Lecroy 9374L) by coaxial cable (type: 5D-2V, connector: BNC, length: 30m). The EM waves were digitized at a sampling rate 500 MHz by using a DSO controlled by a personal computer (PC) through GPIB board. To detect pulse-train EM waves, we applied a sequential triggering technique for each EM pulse. We divided the whole memory of DSO into 1000 segments, and each segment can record one wideband EM pulse for time window of 2  $\mu\text{s}$ . Once the EM pulse from electrical discharge is detected and its amplitude exceeds a threshold value (triggered level), a triggering circuit is turned on to record a waveform and saves it as one segment with resolution 8 bits. Then, the system returns back to wait for triggering the next signal. With this technique, we can record maximum 1000 wideband EM pulses in each measurement. Note that the minimum time between two consecutive EM pulses is about 70  $\mu\text{s}$  due to instrumentally dead time.

### 3. Results

#### 3.1 Single pulse analysis

**3.1.1 Fourier and wavelet analyses** To analyze the waveform of a single pulse, we employ two kinds of signal processing techniques, which are Fourier and wavelet transforms. Fourier transform is a well-known tool for extracting the average spectral intensities of a signal over the analyzing window. However, in case of the non-stationary signal such as EM pulse,

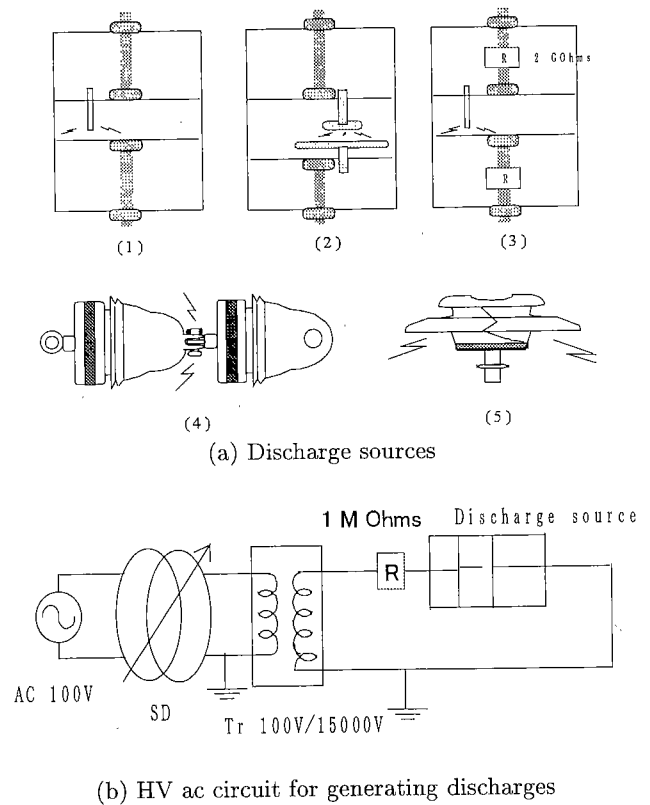

Fig. 1. Generation of electrical discharges.

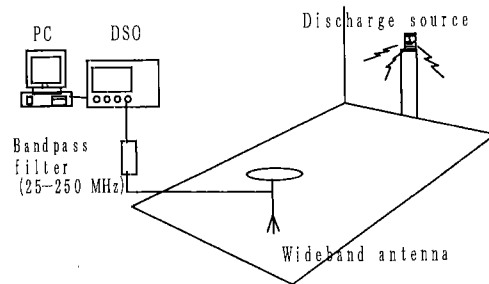

Fig. 2. An experimental configuration.

the time-varying information of a spectrum is required to analyze a waveform and it would be difficult if we use Fourier transform alone. Therefore, to overcome the limitation of Fourier transform, wavelet transform has been applied to perform time-frequency analysis in numerous problems<sup>(6)-(8)</sup>. In this paper, we use both the fast Fourier transform (FFT) and the continuous wavelet transform with Gabor function<sup>(8)</sup> as a mother wavelet, to extract the average and time-varying spectral intensities, respectively. The spectrum on the frequency range 0-250 MHz with the resolution 0.488 MHz is determined by FFT. In case of wavelet transform, the same frequency range 0-250 MHz with the resolution 25 MHz and the time period 0-2000 ns with the resolution 2 ns are considered. Note that the normalized values of spectral intensities are used to express the FFT and wavelet analyses in order to compare the results fairly.

#### 3.1.2 EM environment at an experimental site

Figure 3 (a) shows the EM environment (background

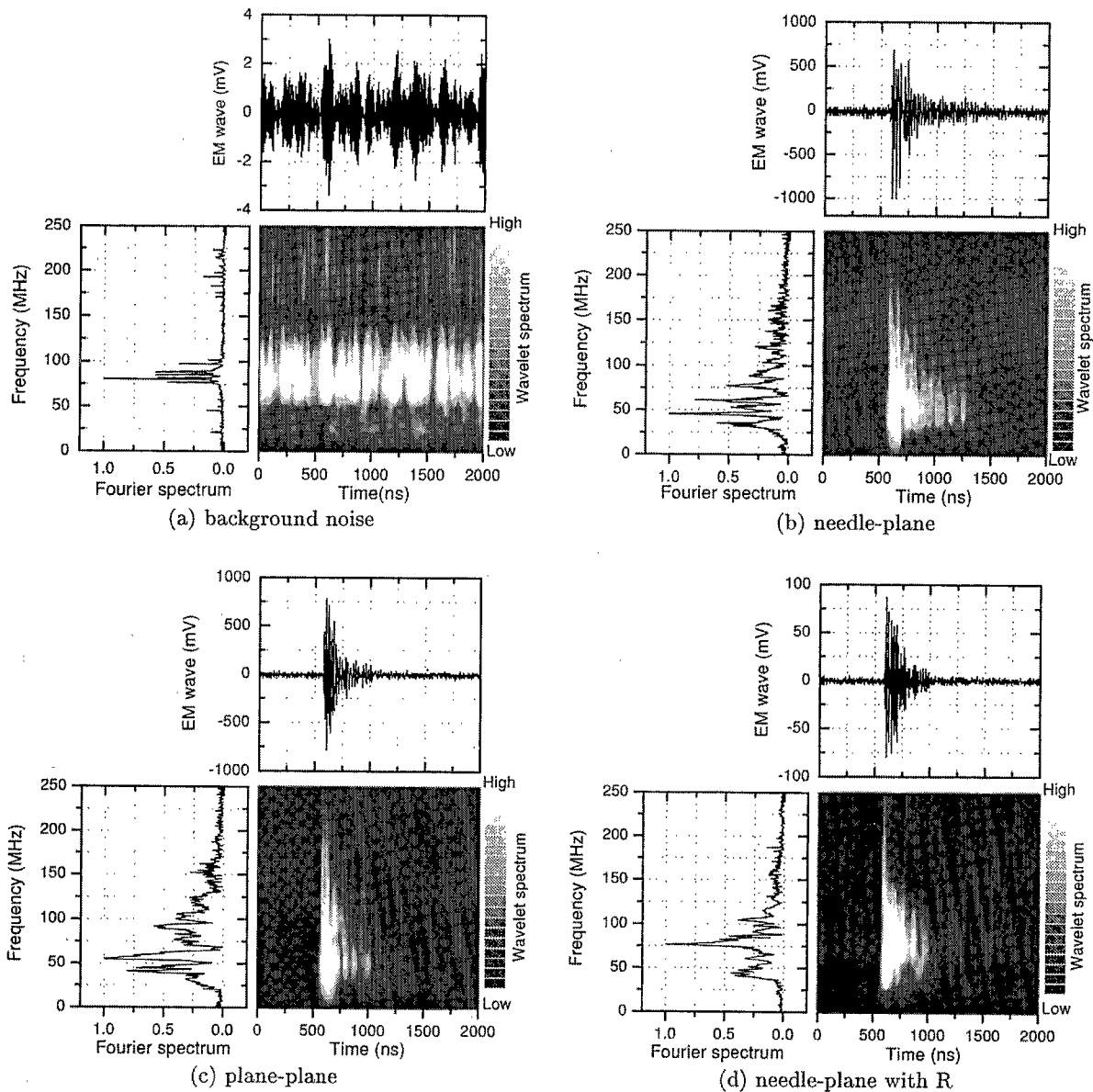

Fig. 3. Typical results of EM pulses emitted from various electrodes.

noise) and its Fourier and wavelet analyses. The peaks in the Fourier spectrum are thought to be the signals from radio and television broadcastings. In Japan, the frequency range 76.1~89.9 MHz is accordant with FM radio signals. The peaks in the frequency range 90~108 MHz are supposed to be the signals from the channels 1~3 of TV broadcasting. The peaks in 170~222 MHz are expected to be the signals from the TV channels 4~12. Moreover, from the same Fig., the wavelet spectrum exhibits the continuous occurrence of these broadcasting frequencies. These results confirm that the broadband VHF signals were correctly measured by the antenna used in this experiment.

**3.1.3 EM pulse from discharge sources** Figures 3 (b)-(d), 4 and 5 show the waveforms of EM pulses from various discharge sources and their Fourier and wavelet analyses. Normally, the pulse begins at 600 ns of time window 2  $\mu$ s because we set the pre-triggered time at 30 [%] and its duration is different from each

other depending on the kind of a source.

Figures 3 (b)-(d) illustrate the typical results of EM pulses emitted from needle-plane electrode, plane-plane electrode and needle-plane electrode with resistances, respectively. Considering these waveforms, the pulse-width is about 500 ns. From FFT analysis, all cases exhibit the similar features that there are high spectral intensities and some sharp peaks in frequency range 25-150 MHz. In addition, we also obtain the similar time-varying information from wavelet analysis that there are mainly high spectral intensities in frequency range 25-150 MHz of time 600-800 ns, and little lower intensities in frequency range 25-100 MHz of time 800-1100 ns.

Figure 4 illustrates the typical results of EM pulses when we applied the dc high-voltage on the needle-plane electrode. The results, when applying the plus (+) side of dc power supply on needle and plane, are shown in Figs. 4 (a) and (b), respectively. As can be seen, the similar results as shown in Figs. 3 (b)-(d) are obtained.

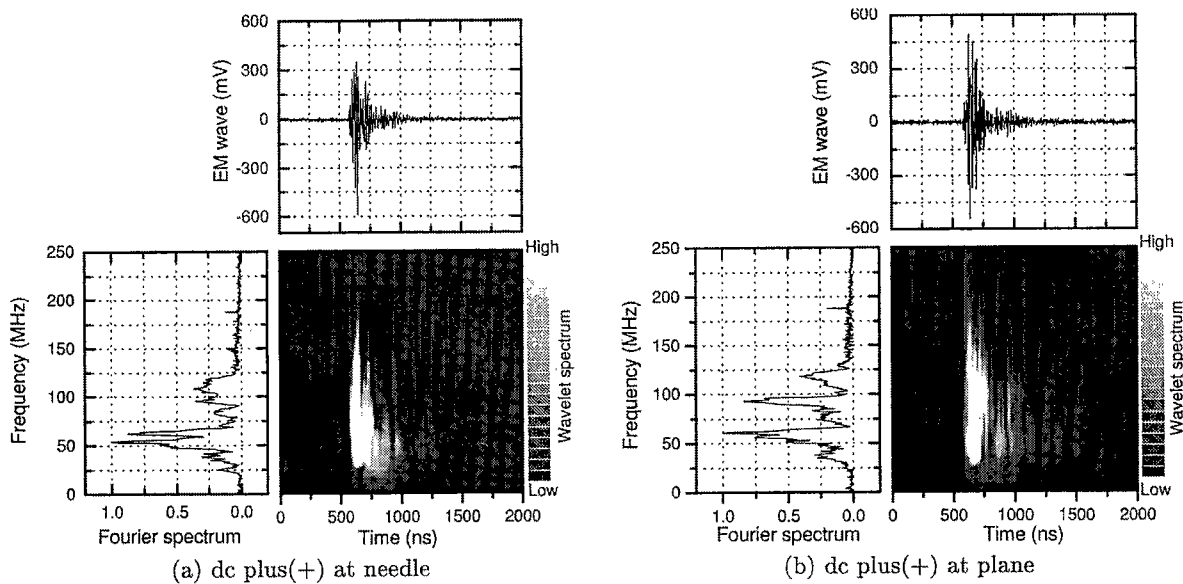

Fig. 4. Typical results of EM pulses emitted from needle-plane electrode when applying dc high voltage.

Considering the EM pulses from faulty insulators, in case of strain insulators, there are two main kinds of waveforms as shown in Figs. 5 (a) and (b). The former (Fig. 5 (a)) and the latter (Fig. 5 (b)) are the typical results from the experiments during summer and winter, respectively. The former is similar to the results in Fig. 4 (discharge in air gap). On the contrary, the pulse width of the latter is around 200 ns which is shorter than the former. These results show that the EM pulse from this kind of discharge may be different due to an environmental condition even we equally wrapped the insulated tape on the cotter pin.

In case of a pin-type insulator, the results are shown in Fig. 5 (c). The amplitude of EM pulse is only little higher than that of background noise. There are the highest peak and some lower ones occurring around 25 MHz in Fourier analysis and they are supposed to be the signal from the discharge. The other peaks are thought to be the signals from radio and television broadcastings. From the wavelet analysis, there are apparently high spectral intensities in frequency range 25-50 MHz of time 500-800 ns. Moreover, there are lower spectral intensities continuously occurring all over the time window in frequency range 75-100 MHz. This confirms that these frequency components are from the broadcasting signals.

**3.2 Time-sequential pulse-height (TSPH) analysis** As previously concerned, the proposed system can detect a lot of EM pulses in each measurement. In this subsection, we investigate the statistical pattern of EM pulses or so-called *time-sequential pulse-height (TSPH)* pattern. Table 1 shows the average time interval between two consecutive EM pulses which greatly varies with a kind of discharge source. The shortest time interval belongs to needle-plane electrode but the longest one belongs to pin-type insulator.

Figures 6 (a)-(d) show the examples of time-

sequential pulse-height (TSPH) patterns of EM pulses from various sources (ac high voltage). The heights of EM pulses or *EM pulse peaks* in the first 50 ms are plotted. The EM pulses appear periodically every 17 ms which corresponds to the system period (60Hz). In case of needle-plane electrode, the discharge mechanism exhibits polarity difference that the number and amplitude of positive pulses are not equivalent to those of negative ones. The amplitude of negative pulses is smaller but the number of them is more than that of positive ones. For the rest discharge sources, there is no specific polarity difference. Considering the plane-plane electrode, both positive and negative pulses occur in the ac half cycle with almost same number but various pulse-heights. From Figs. 6 (c) and (d), the result of the needle-plane electrode with resistances is looked like that of strain insulators. The number and height of positive pulses equal to those of negative ones in each ac half cycle. Note that the TSPH result of the pin-type insulator is not shown due to its too slow phenomenon. Figure 6 (e) shows the typical TSPH patterns when applying dc high voltage on needle-plane electrode in the first 100 ms. Only the negative pulses appear and we obtain the similar results when applying plus (+) side of dc power supply on the needle and plane. The interval between consecutive pulses and pulse-height are normally unchanged. The pulse interval (around 23 ms) is much longer than those of discharge sources, which

Table 1. Average time interval between EM pulses (ac high voltage).

Discharge source	Time interval (ms)
1. needle-plane	0.296
2. plane-plane	0.447
3. needle-plane(with R)	3.939
4. strain insulators	2.095
5. pin-type insulator	107.9

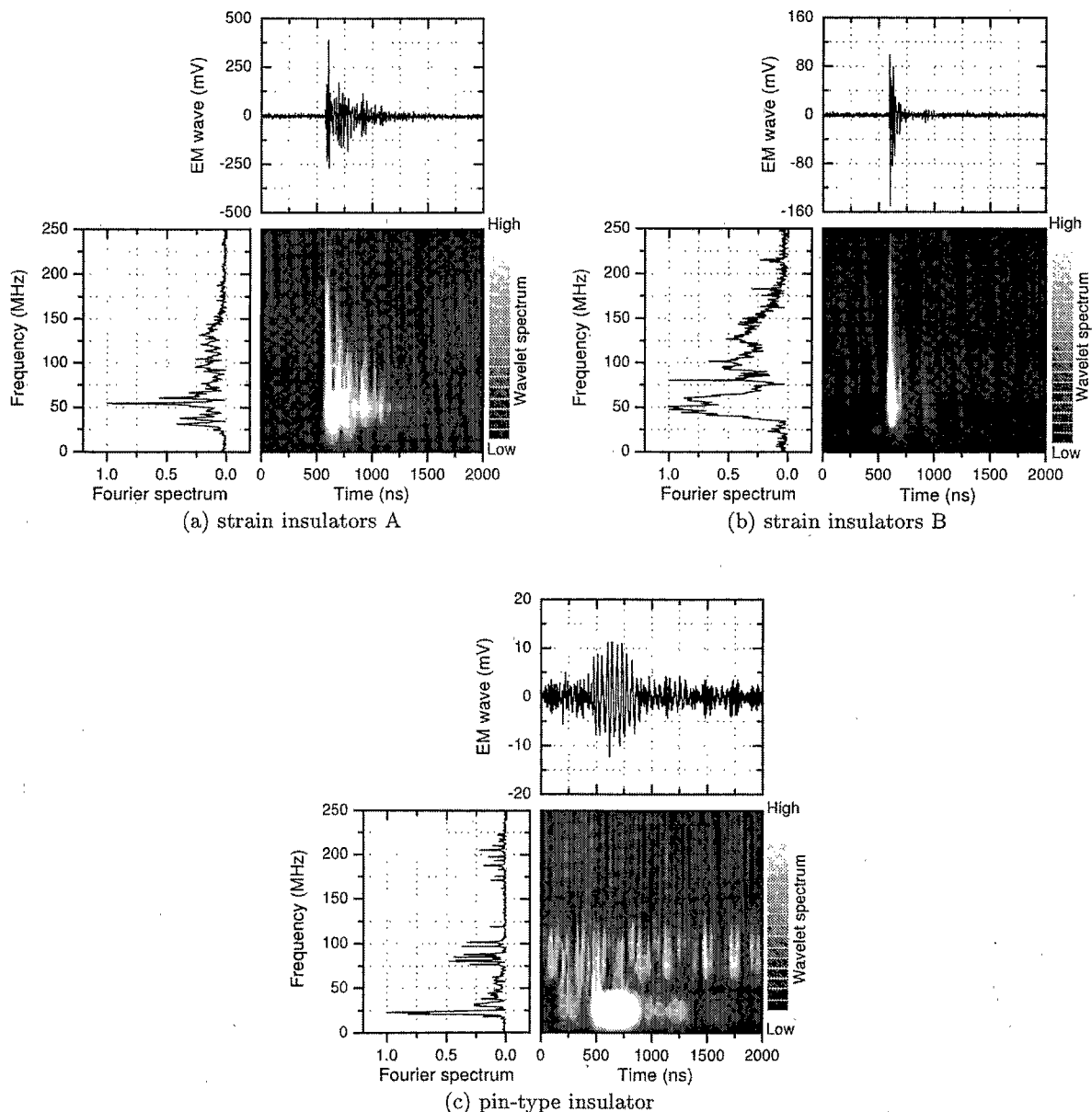

Fig. 5. Typical results of EM pulses emitted from faulty insulators.

were generated by ac high voltage.

#### 4. Discussions

**4.1 Single pulse analysis** From a single pulse analysis, we can conclude that the feature of an EM pulse is oscillating and non-stationary. Its time-varying information depends on the discharge mechanism, which relates to the kind of a source. The mechanism of discharges is discussed and explained as follows.

From Figs. 3 (b)-(d) and 4, we discuss that the EM pulses were generated from the discharge occurred in small air gap. In air, the discharge is initiated from an electron avalanche process whereby neutral molecules are ionized by electron impacts under the effects of the applied field. Once the discharge is generated, the electrons around neutral molecules are excited to higher energy level, which is unstable. Then, the electromagnetic waves are radiated from them to return to normal

state. Since, air is normally a particular mixture of nitrogen [79%], oxygen [20%], and various impurities, the radiation process in the same material should result the similar characteristics of electromagnetic pulses, which are independent of the kind of electrode and power supply (ac or dc). Therefore, the results of pulse characteristics in Fig. 3 (b)-(d) and 4 are quite similar to each other.

In case of faulty strain insulators in Fig. 5 (a) and (b), it is discussed that this kind of discharge is generated from the gap, which includes air and insulated tape, at the faulty contact between two insulators. Its mechanism is initiated from the electron avalanche like the discharge in air gap. Therefore, the result of Fig. 5 (a) is similar to the previous result in case of discharge in air. In order to explain the reason why the result of Fig. 5 (b) differs from that of Fig. 5 (a), the humidity at an experimental site is considered. The result of

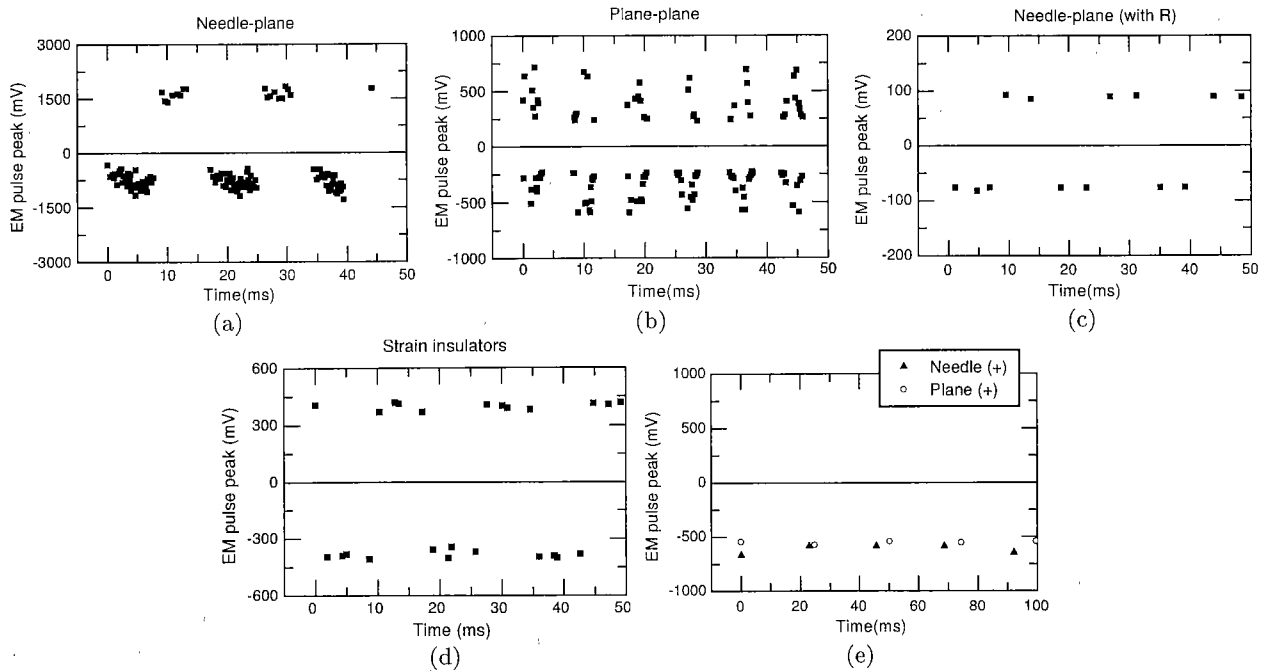

Fig. 6. Time-sequential pulse-height patterns of emitted EM pulses.

Fig. 5 (a) was obtained during winter whose humidity is much lower than that of summer. The impedance of discharge gap under lower humidity should be higher. Therefore, the discharge might not consistently occur for a long time that made the pulse width shorter. Finally, considering the mechanism of discharge at the faulty pin-type insulator, this discharge was caused by the degradation of insulation, which includes the voids inside the insulator and the stained surface. The leakage current could flow more continuously due to the cracked insulator. It is discussed that this kind of discharge mechanism emits the EM pulses, which exhibit the low-frequency components.

In summary, the characteristics of a single pulse are different depending on the kind of a discharge source and the environmental condition. From the results, we can discriminate the PD caused by pin-type insulator from the others by considering the spectrum of an emitted EM pulse. However, it is still difficult to identify the other sources by using only this information.

#### 4.2 Time-sequential pulse-height (TSPH) analysis

From Table 1, it is clearly seen that the occurrence of emitted EM pulses depends on a kind of discharge source. The most frequent one is a needle-plane electrode. It is discussed that the electric charges can be easily accumulated and discharged due to a small area of a needle tip. In case of needle-plane electrode with resistances and strain insulators, there are resistances connected on both ends of discharge sources so it takes more time to accumulate electric charges to generate discharge. For pin-type insulator, it is believed that the discharge is caused by the degradation of insulation so the discharge does not occur from permanent gap. If the leakage current flows completely through the insulator,

the discharge will not occur in some cycles of applied voltage.

Considering the TSPH patterns, all results show the systematic relation with the period of applied voltage of ac system. In case of needle-plane electrode, the electromagnetic pulses show a strong polarity difference that the amplitude of positive pulses is higher than that of negative ones. However, the number of positive pulses is smaller. This result is accordant with a previous investigation of the characteristic of discharge current pulses<sup>(10)</sup>. Therefore, there is a possibility to forecast the current pulses by measuring electromagnetic pulses.

As for plane-plane electrode, we used different sizes of metallic plates whose the upper one is smaller. Considering the electric field in this case, the distribution of electric field between two plates is not equivalent in the outer part of the upper one. On the contrary, the electric field in the inner part lines linearly between two plates, so its distribution is almost equivalent. The discharge phenomenon normally initiates from the strongest electric field, which is generally in the inner part. With this reason, we discuss that the polarity ( $\pm$ ) of applied voltage does not influence or little influences this kind of a discharge phenomenon. The pulse-height distribution of both negative and positive pulses is rather high. It is believed that applying high voltage on plane-plane electrode steadily increases the electric-field stress on air molecules between them. Before all electrons return to a normal state, some of them are additionally excited to the higher energy levels. There are various pulse-heights of electromagnetic pulses occurring because the radiation of electromagnetic waves is caused by the recovery to the normal state from various higher levels of the electrons.

In case of needle-plane electrode with resistances, the applied voltage across air gap is greatly decreased and each side is equal to one resistance lump due to a big resistance component connected on each side. Therefore, the EM pulses do not exhibit a polarity difference. For faulty strain insulators, the result is similar to that of needle-plane electrode with resistances because the equivalent circuit of an insulator includes a high impedance part. It is also discussed that the needle-plane electrode with resistances can be successfully used to simulate the faulty contact of two strain insulators.

Considering the discharge generated by dc power supply, the applied voltage is normally constant so the energy is steadily transmitted to air molecules. Therefore, the pulse amplitude and the time interval between consecutive pulses are constant. There is no difference on whichever side of an electrode, the dc (+) of power supply connected to, excepting that the time interval in case of dc (+) connected to needle is little shorter. From these results, the TSPH patterns in case of dc source are clearly different from those of ac source. Therefore, we can classify the discharge is from whether ac or dc system.

In summary, the TSPH pattern of EM pulses has its own characteristics depending on the kinds of a discharge source and applied voltage. It has been shown that we can classify the source more efficiently if we analyze this TSPH pattern of pulses associated with the single pulse analysis.

## 5. Conclusions

The VHF wide-band pulse-train electromagnetic noises emitted from various sources of discharges have been investigated. We analyzed both the characteristics of a single electromagnetic pulse and the time-sequential pulse-height pattern of a lot of pulses obtained in the experiment. The characteristics of a single pulse waveform were analyzed by digital signal processing techniques which are Fourier and wavelet transforms. Fourier and wavelet analyses provide the average spectral intensities and their time-varying information of an emitted pulse, respectively. It has been shown that wavelet analysis is advantage to identify the spectrum generated by broadcasting signals from that caused by the discharge. Moreover, we can know the pulse-height and pulse-repetition of both positive and negative electromagnetic pulses from the time-sequential pulse-height pattern. From these results, we can interpret the mechanisms of discharges more clearly. It has been shown that the results are useful to classify the kinds of discharges and assess the condition of insulators in distribution systems.

In the future, we plan to monitor and analyze the discharge phenomena in real-time. In order to obtain more accurate characteristics of electromagnetic pulses from the discharges, the de-noising technique will be developed and applied before analyzing signals. The automatic classification and location system will be designed and constructed based on signal processing techniques

and artificial neural networks.

(Manuscript received December 11, 2000, revised July 6, 2001)

## References

- (1) NHK Training center, *The effect of pulsed noise from distribution lines and its measurement*, 1996 (in Japanese).
- (2) M. Kawada, Z-I. Kawasaki, K. Matsu-ura, and M. Kawasaki, *Non-contact detection of electromagnetic noise occurrence due to partial discharges by spatial phase difference method*, Trans. IEE Japan, Vol. 115-B, No. 10, 1995, pp. 1168-1173 (in Japanese).
- (3) Y. Suzuki, M. Kawada, Z-I. Kawasaki, K. Matsu-ura, and M. Kawasaki, *Location of partial discharge by superimposed positioning optimization on the time delay of arrival*, Trans. IEE Japan, Vol. 118-B, No. 2, 1998, pp. 157-163 (in Japanese).
- (4) A. Tungkanawanich, Z-I. Kawasaki, K. Matsu-ura, *Location of Multiple PD Sources on Distribution Lines by Measuring Emitted Pulse-Train Electromagnetic Waves*, Trans. IEE Japan, Vol. 120-B, No. 11, 2000, pp. 1431-1436.
- (5) C. H. Peck, P. J. Moore, *A direction-finding technique for wide-band impulsive noise source*, IEEE Trans. on Electromagnetic Compatibility, Vol.43, No.2, May 2001, pp. 149-154.
- (6) Charles K. Chui, *An introduction to wavelets*, Academic Press, Inc., 1992.
- (7) Oinis Chaari, Michel Meunier, Francoise Brouaye, *Wavelet: A new tool for the resonant grounded power distribution systems relaying*, IEEE Trans. on Power Delivery, Vol.11, No.3, July 1996, pp. 1301-1308.
- (8) A. Tungkanawanich, Z-I. Kawasaki, K. Matsu-ura, *Ground Fault Discrimination based on Wavelet Transform using Artificial Neural Networks*, Trans. IEE Japan, Vol. 120-B, No. 10, 2000, pp. 1263-1270.
- (9) J. Abe, A. Tungkanawanich, R. Mardiana, Z-I. Kawasaki, and K. Matsu-ura, *The characteristic of VHF broadband pulse caused by corona discharge*, Technical report of IEICE, EM CJ-99-52, 1999-09 (in Japanese).
- (10) M. Hikita, T. Kato, and H. Okubo, *Partial discharge measurements in SF6 and air using phase-resolved pulse-height analysis*, IEEE Trans. on Dielectric and Electrical Insulation, Vol. 1, No. 2, April 1994, pp. 276-283.

**Ampol Tungkanawanich** (Student Member) received a bachelor degree in Electrical Engineering from Chulalongkorn University (Thailand) in 1995. He came to Japan to further his graduate study under the support of Japanese government (Monbusho scholarship). He received a master degree from Department of Electrical Engineering, Osaka University in 1999 and is currently pursuing a Ph.D. degree there. His research mainly deals with HV engineering, electromagnetic compatibility and signal processing.

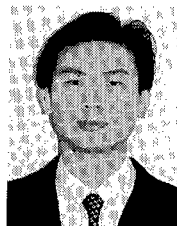

**Zen-Ichiro Kawasaki** (Member) received his B.S., M.S. and Dr. Eng. degrees in Communication Engineering from Osaka University in 1973, 1975 and 1978, respectively. In 1989, he joined the Department of Electrical Engineering, Osaka University. At present, he is a professor of the Department of Communication Engineering. His research mainly concerns the observation of lightning, and the diagnostic techniques for power equipment. Dr. Kawasaki is also a member of the Society of Atmospheric Electricity of Japan.

